



US0D1111741S

(12) **United States Design Patent**  
**Chen**

(10) **Patent No.:** **US D1,111,741 S**

(45) **Date of Patent:** **\*\* Feb. 10, 2026**

(54) **RETRACTABLE RATCHET TIE-DOWN**

(71) Applicant: **Zhangjiagang City Xiangle Tool Co., Ltd.**, Suzhou (CN)

(72) Inventor: **Zhilong Chen**, Jiangsu (CN)

(\*\*) Term: **15 Years**

(21) Appl. No.: **35/521,474**

(22) Filed: **May 30, 2024**

(80) **Hague Agreement Data**

Int. Filing Date: **May 30, 2024**

Int. Reg. No.: **DM/237872**

Int. Reg. Date: **May 30, 2024**

Int. Reg. Pub. Date: **Jun. 28, 2024**

(30) **Foreign Application Priority Data**

Apr. 18, 2024 (CN) ..... 202430218440.9

(51) **LOC (15) Cl.** ..... **08-05**

(52) **U.S. Cl.**  
USPC ..... **D8/44**

(58) **Field of Classification Search**

USPC ..... D8/44, 45, 107, 394, 396  
CPC ... B65H 75/40; B65H 2701/37; B60P 7/0846;  
B60P 7/083; B21F 9/02; B65B 13/025  
See application file for complete search history.

(56) **References Cited**

**U.S. PATENT DOCUMENTS**

3,844,317	A	*	10/1974	Angarola	.....	B21F 9/02 140/93.2
D661,562	S	*	6/2012	Stevens	.....	D8/44
D675,498	S	*	2/2013	Stevens	.....	D8/44
D700,487	S	*	3/2014	Deshpande	.....	D8/44
D729,026	S	*	5/2015	Qin	.....	D8/44
D821,172	S	*	6/2018	Romanak	.....	D8/44
D821,837	S	*	7/2018	Romanak	.....	D8/44
D861,448	S	*	10/2019	Zhang	.....	D8/44
D876,915	S	*	3/2020	Romanak	.....	D8/44

D877,587	S	*	3/2020	Romanak	.....	D8/44
D894,701	S	*	9/2020	Repic	.....	D8/44
D939,910	S	*	1/2022	Hu	.....	D8/44
D987,398	S	*	5/2023	Hernandez, Jr.	.....	D8/44
D1,012,645	S	*	1/2024	Chen	.....	D8/44

(Continued)

**FOREIGN PATENT DOCUMENTS**

CN D237872-001 \* 6/2024

**OTHER PUBLICATIONS**

Xiangle, Endless Stainless Steel Ratchet, [no date avial], searched Apr. 9, 2025, <https://www.xiangletools.com/ratchet-straps/1-5-ratchet-strap/1-5-ratchet-straps-38mm.html> (Year: 2025).\*

(Continued)

*Primary Examiner* — Calvin E Vansant

*Assistant Examiner* — Olivia H Aldin

(57) **CLAIM**

The ornamental design for a retractable ratchet tie-down as shown and described.

**DESCRIPTION**

- 1. Retractable ratchet tie-down
- 1.1 : Front
- 1.2 : Back
- 1.3 : Left
- 1.4 : Right
- 1.5 : Top
- 1.6 : Bottom
- 1.7 : Perspective
- 1.8 : Perspective

Purpose of the design product: this product is used in conjunction with a tensioner bundling strap to secure and transport goods, and the bundling strap is tightened and loosened by a ratchet system.

The broken lines depict portions of the retractable ratchet tie-down that form no part of the claimed design.

**1 Claim, 8 Drawing Sheets**

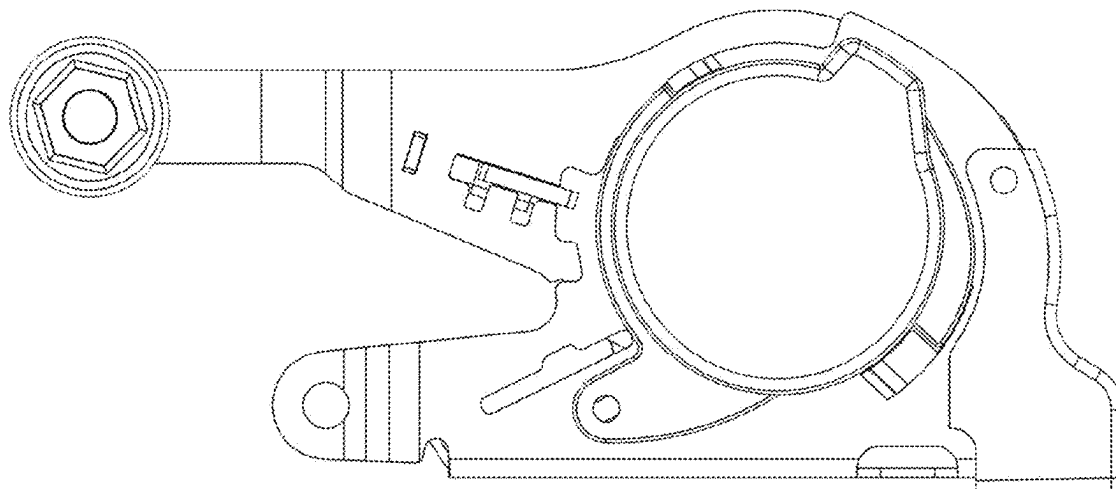

(56)

**References Cited**

U.S. PATENT DOCUMENTS

D1,048,863 S \* 10/2024 Hatcher ..... D8/44  
D1,054,813 S \* 12/2024 Ren ..... D8/44  
2009/0119892 A1 \* 5/2009 Breeden ..... B60P 7/083  
24/68 CD  
2012/0241545 A1 \* 9/2012 Borntrager ..... B65H 75/40  
242/395

OTHER PUBLICATIONS

Amazon, Ratchet Straps, Jun. 7, 2024, <https://tinyurl.com/3829fmjs>  
(Year: 2024).\*

\* cited by examiner

1.1

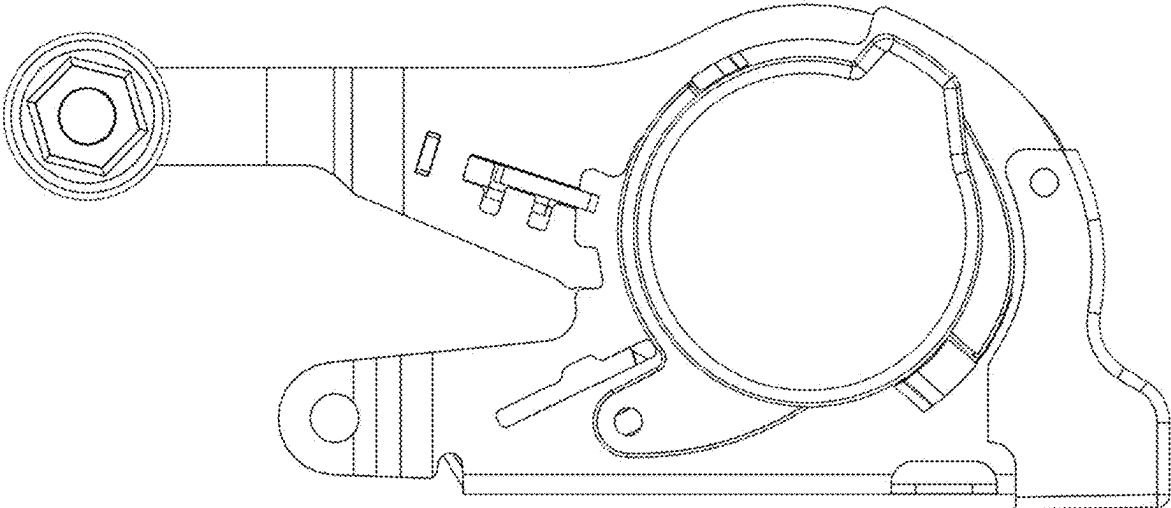

1.2

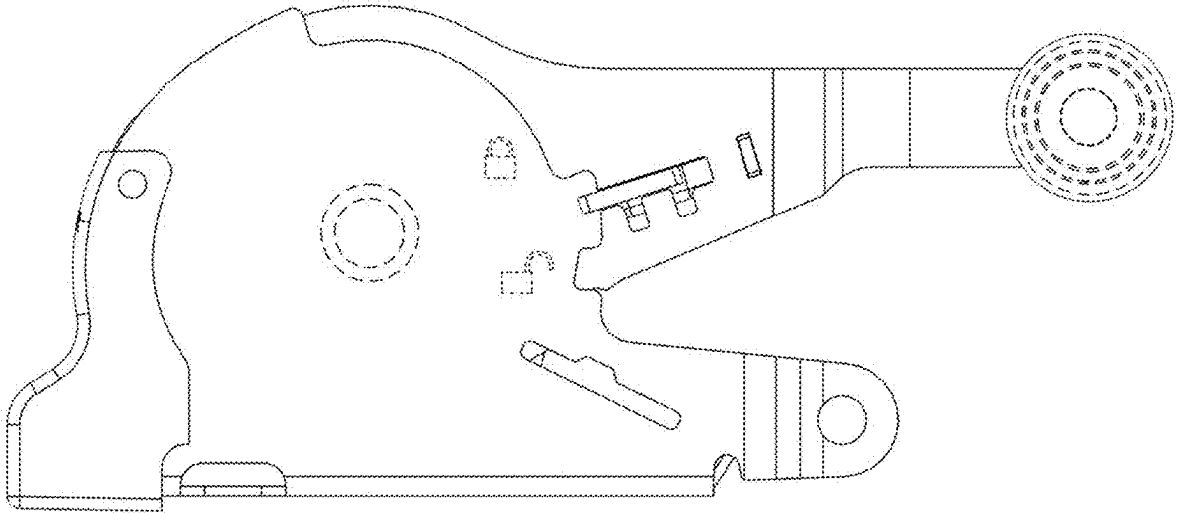

1.3

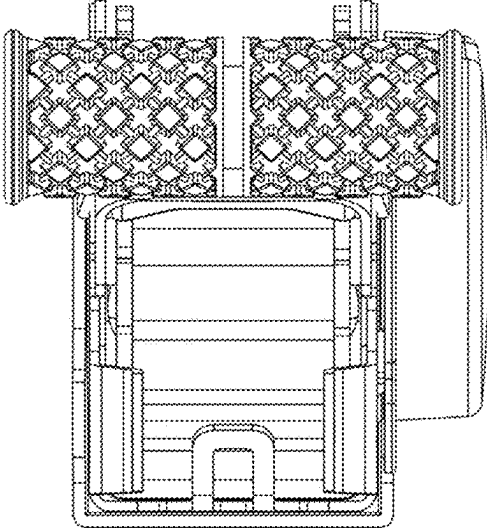

1.4

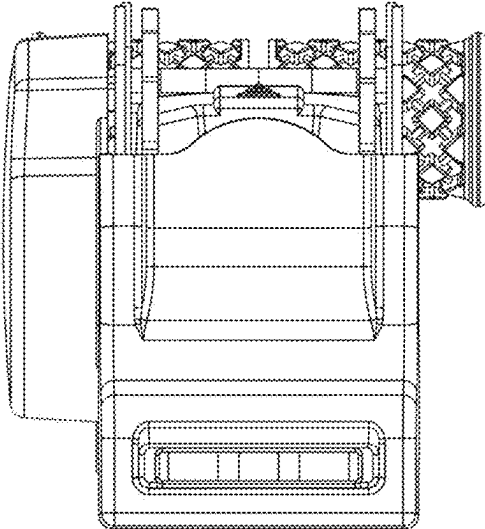

1.5

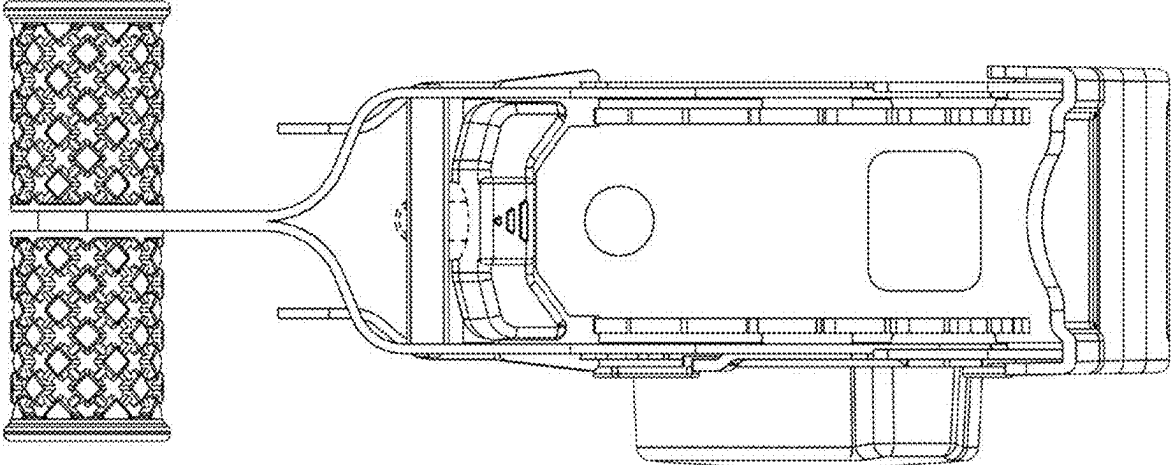

1.6

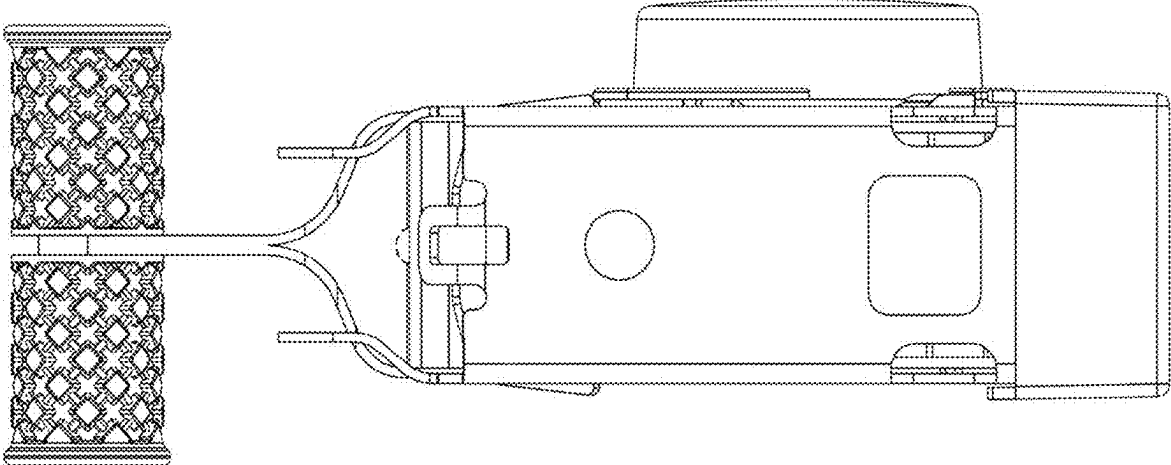

1.7

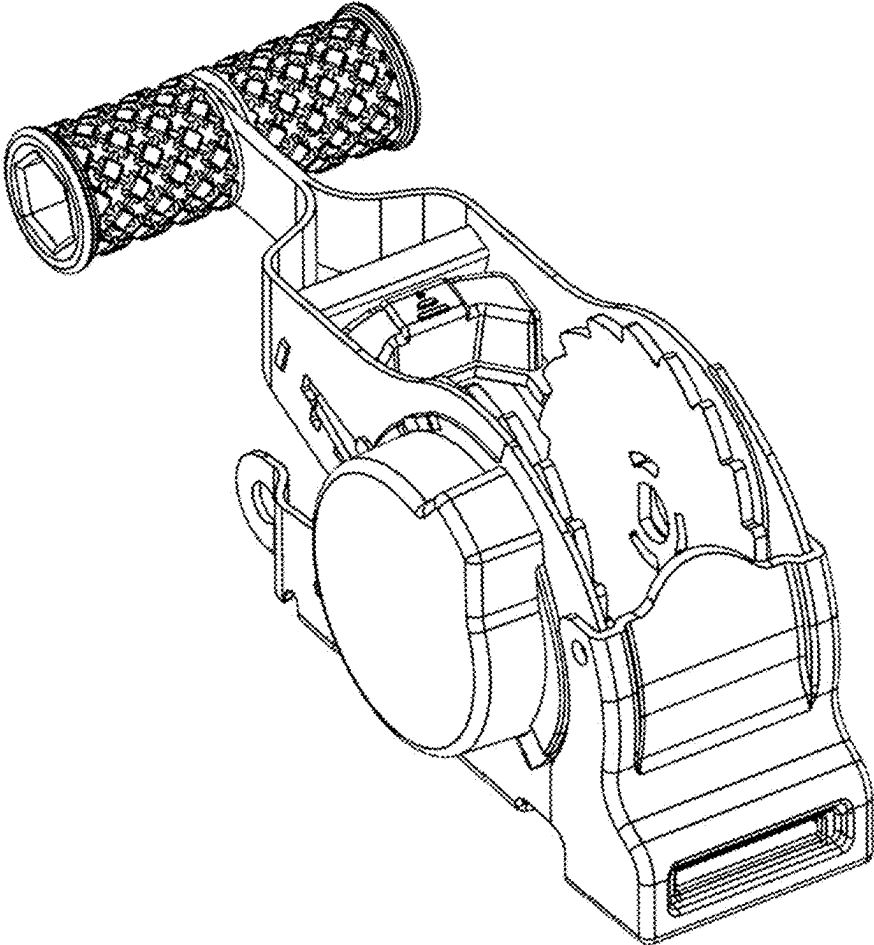

1.8

